

DAISY -55EC / -63EC

Instruction Manual

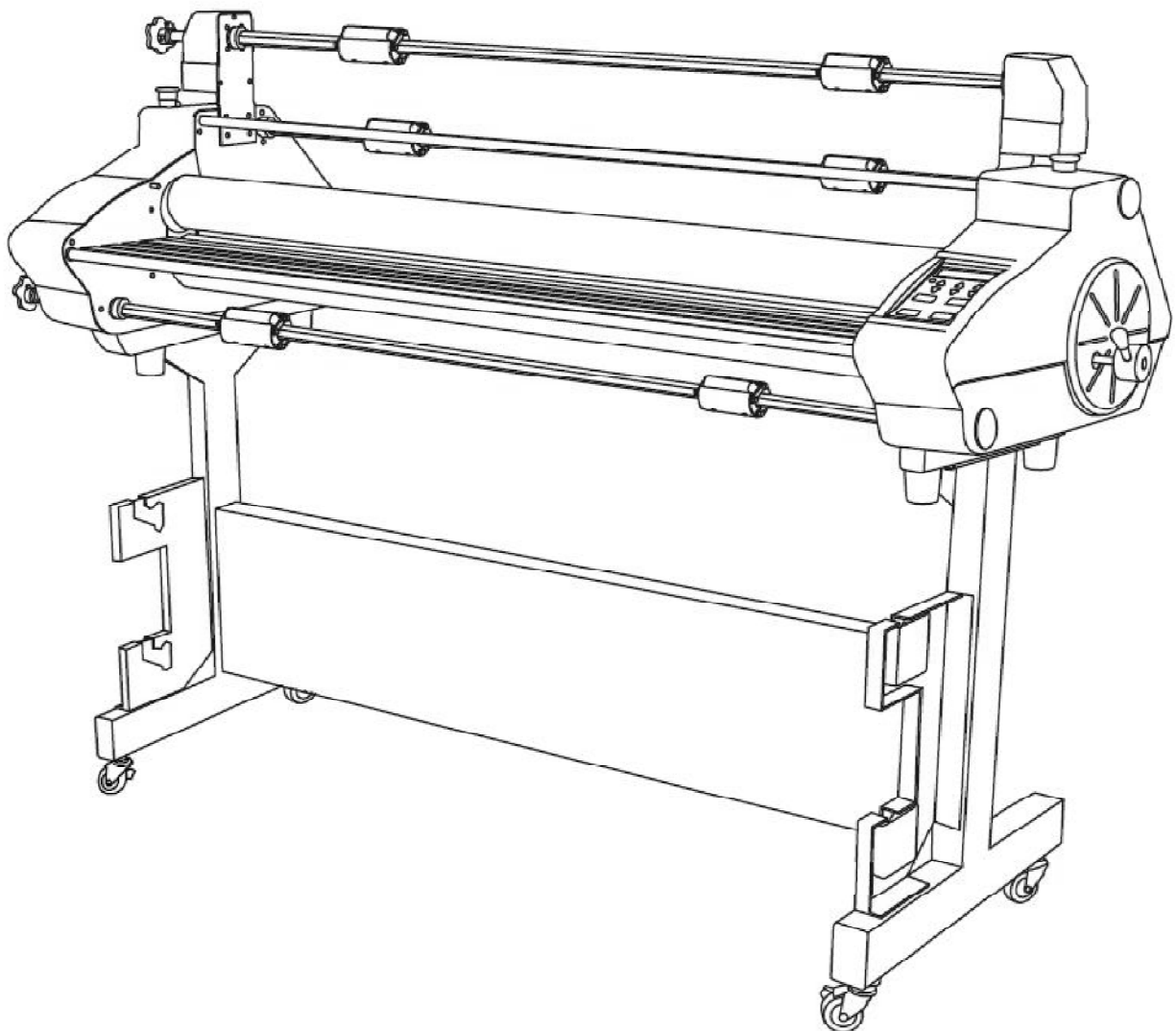

LAMI CORPORATION INC.

Preface

Thank you for purchasing our [**DAISY-55EC /-63EC**].

This Instruction Manual (document) includes details for safe use of this product.

Please read this document thoroughly before using the product.

Also, carefully store this document for immediate use whenever necessary.

Table of Contents



■ Preface	P 1
└ Table of Contents	P 1
■ Precautions Before Use	P 2
└ List of Labels Attached to the Product and Meaning of Symbols	P 2
└ Precautions for Handling	P 3
└ Place for Installation	P 4
■ Characteristics and Confirmation of Parts	P 5
■ Installation of the Machine	P 6
└ Stand Assembly Method	P 6
└ Foot Switch Installation Method	P 6
└ Power Connection for re-winding Device (Optional)	P 6
└ Fuse Installation Method	P 7
■ Name of Each Part	P 8
└ Main Body of DAISY-55EC/63CE	P 8
└ Operation Panel	P 9
└ Foot Switch	P 10
■ Before Processing Laminate	P 11
└ About Laminate Film	P 11
■ Cold Laminate Processing	P 12
└ Installation and Processing of Cold Laminate Film	P 12
■ Maintenance	P 15
└ Cleaning of Roller	P 15
└ Cleaning of paper tube holder	P 15
└ Cover the product with cloth after use	P 15
■ Troubleshooting	P 16
└ Power does not turn on · machine does not function	P 16
└ Product malfunctions or power is immediately turned off	P 16
└ Wrinkles are formed in the processing material	P 16
└ Processing material cannot be inserted · does not come out	P 16
■ Others	P 17
└ Product Specifications	P 17
└ Contact	P 17









DAISY -55EC /-63EC

Precautions Before Use

Meaning of Symbols

This document uses symbols to explain the degree of harm and damage caused by incorrect use of the product and to prevent harm on customers and others or damage on properties.









 Warning	If this symbol is neglected and the product is handled incorrectly, serious injury or death may occur.
 Caution	If this symbol is neglected and the product is handled incorrectly, human injury or physical damage on properties may occur.

 This symbol indicates matters to be followed to avoid injury.	 This symbol prohibits disassembly of the device for safety.
 This symbol instructs the user to remove power plug from the outlet for safety.	 This symbol prohibits touching of the product with wet hands.
 This symbol instructs the user to connect grounding for safety.	 This symbol prohibits wetting of the product by water.
 This symbol warns the user about the risk of hands rolling into the roller.	 This symbol shows concern for electric shock under improper handling.
	 This symbol shows concern for smoke and ignition under improper handling.

Precautions for Handling











Warning

	Power cable included in the product must be used. Do not use power supply not indicated on the product.
	Do not place heavy objects on power cable, place cables nearby heating devices, or complex wiring.
	Do not process power cable or use damaged power cable.
	Accurately insert to the end of electrode.
	When inserting power cable, the plug must be held. Excessive bending, twisting or pulling can damage the cable interior and cause electric shock, fire, and failure. ※ Contact our company or store when power cord is damaged.
	Regularly remove power cable from the outlet to clean the root and gap of electrode. Do not insert cable with foreign substances such as dust attached.
	Do not install the product in places with high temperature and humidity or poor ventilation, places with combustible and explosive gas or poisonous gas, places covered with dust, and on top of easily burnt objects. When installing against a wall, the product should be placed at least 50cm away from the wall.
	Do not approach the product to firearms, high temperature, metals, and easily burnt objects. Do not put liquids into the machine.
	Do not disassemble or remodel the machine.
	Do not use the product in abnormal state such as smoke, strange odor, and noise. If such condition is found, immediately turn off the power switch and remove power cable from the outlet before contacting the store or our company. The product must never be repaired by the customer for safety purpose.



Caution

	Power cable must be removed from the outlet when the product is not used for long time.
	Do not insert power cable with wet hands.
	Grounding must be connected before connecting power to power cable. Power cable must be removed before grounding disconnection.
	Especially, keep the product away from children.
	Do not ride the product or put heavy objects on top.
	Do not place the product in unstable places (oscillating place, slanted place, and place with vibration of other machineries). The product may fall down or over to injure persons nearby.
	Avoid direct wind from air conditioner.
	Never block the air vent. Blocked air vent can cause failure or fire from accumulation of internal heat.
	During operation or insertion of laminate, be careful about clothes such as neck tie and necklace and body parts from entering the device.
	When film glue is attached to the laminate roller, squeeze cloth stained with neutral detergent and wipe out. (※ Do not clean with benzene, thinner, or sponge.)
	Lift the roller for laminate processing.
	When the machine is not used, cover with a cloth to keep away from direct light or fluorescent light. Light can result in rapid degeneration of the laminate roller rubber.
	For safety, transport this product after turning the power switch off and removing power cable from the outlet.

Place for Installation

This device shall be installed in the following places.

- **Horizontal and stable place**

Use as slanted or in unstable state may result in adverse effects such as paper return.

Also, unexpected accidents can occur.

- **Place where exclusive power outlet is available**

Do not use power types other than the rated voltage regulated on this Manual.

Grounding and earth leakage breaker must be installed.

- **Place with low humidity and sound ventilation**

Installation of this product in place with high humidity can result in short circuit or failure.

Avoid outdoor places and places with direct light or air conditioner wind.

- **Workability**

Secure sufficient space for workability.

Do not install the product too close to walls. If possible, space between the product and wall should be wide enough to allow human passage.

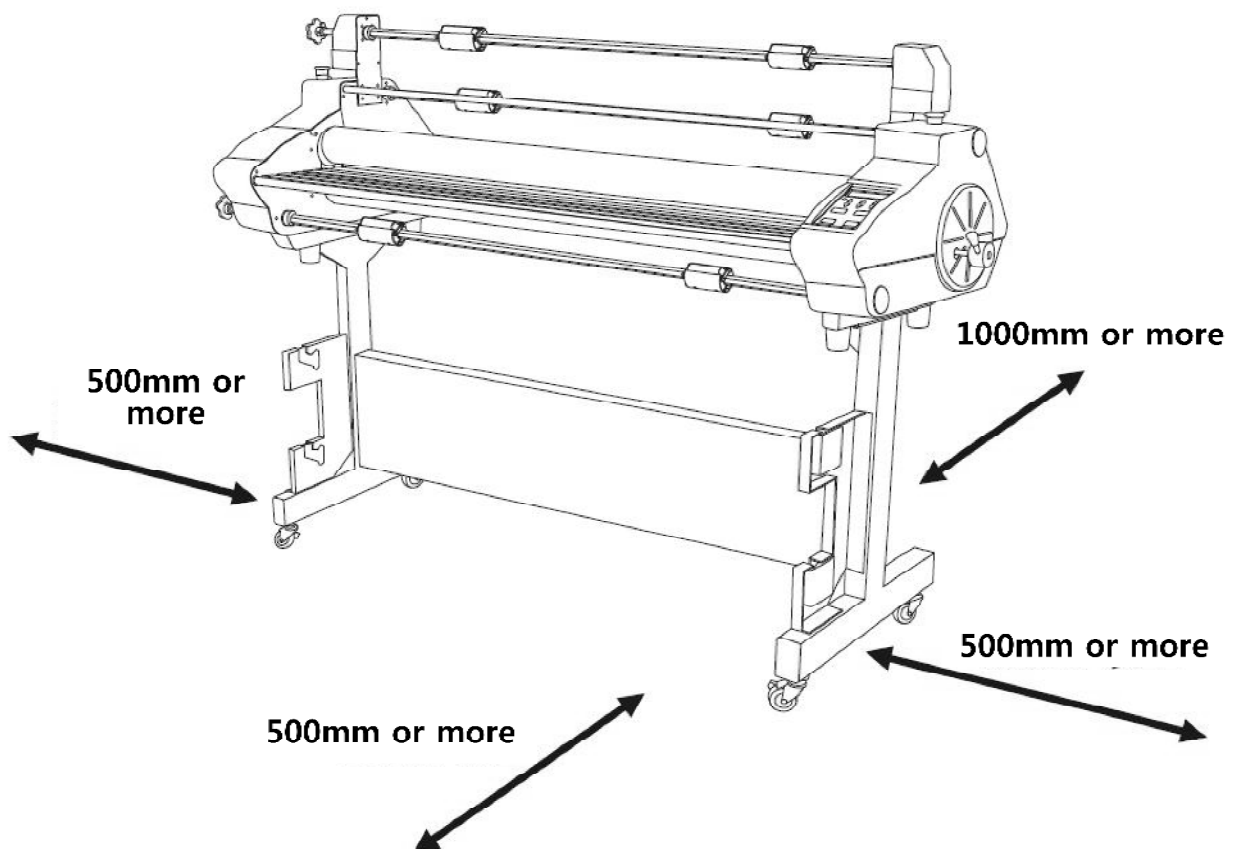

Characteristics

- Pressure can be adjusted in 8 steps using lever
- Speed of laminate processing can be adjusted step by step
- Rotation and stopping of the roller can be done using foot switch
- Transparent safety cover

Confirmation of Parts

The following parts and documents are included in the main body.

If there is a missing part, contact a nearby business office of our company or store from which the product was purchased.

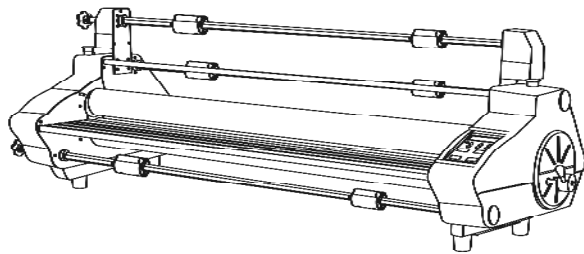

DAISY-55EC /-63EC main body

Film shaft	3 EA
Branch paper tube holder (3-inch)	6 EA
Handle	1 EA

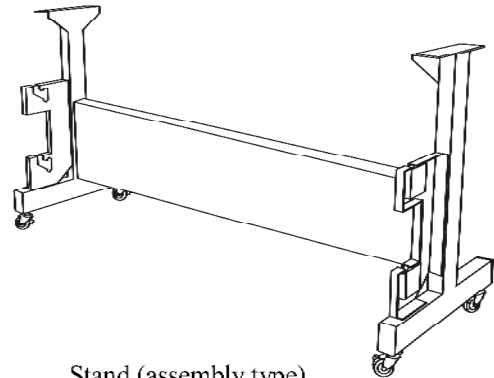

Stand (assembly type)

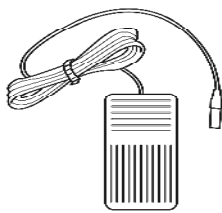

Foot switch



Hex wrench
(For paper tube holder)



Instruction Manual
(this document)



Warranty



Option ①
Media holder shaft

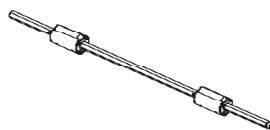

Option ②
Reserve film shaft

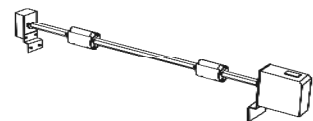

Option ③
Re-Winding device

DAISY -55EC /-63EC

Installation of the Machine

Stand Assembly Method

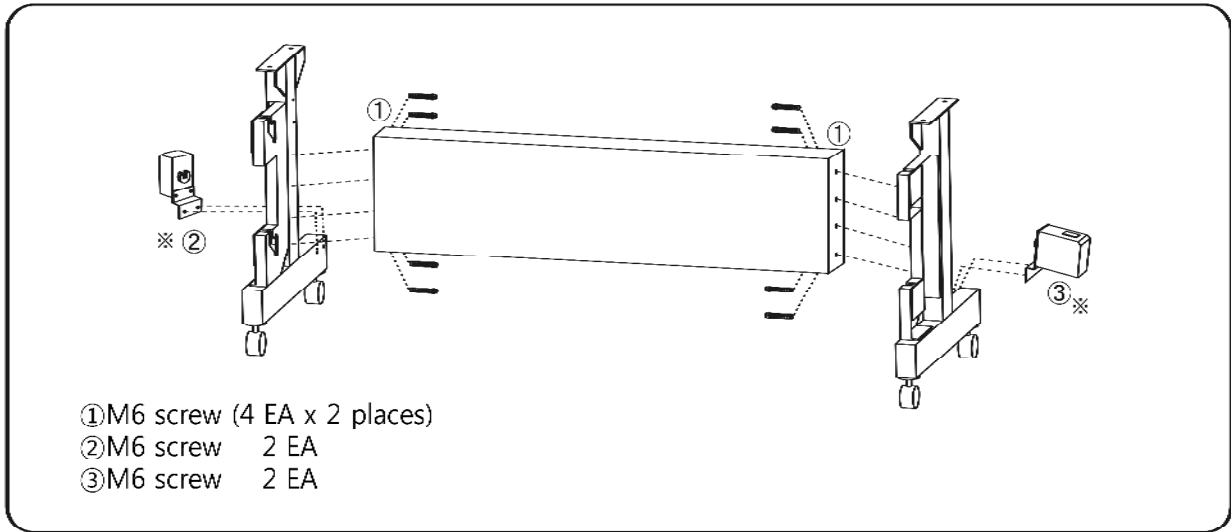

Stand is assembly type. Use hex wrench to install the stand while being careful about left and right directions.

※ ② and ③ are optional.

③ with re-winding power switch should be installed on the right stand when looked from the front.

Foot Switch Installation Method

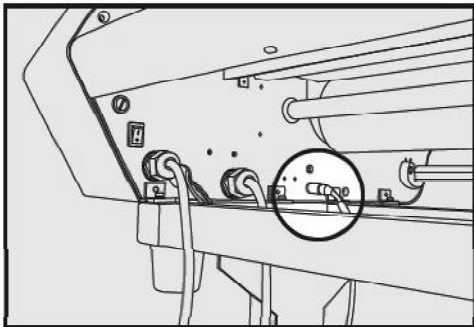

When looked from the front, there is an insertion hole of foot switch at the center of the right surface.

Convex surface prevents insertion in incorrect direction. Check the shape of the insertion hole before inserting.

(Excessive force causes damage the part.)

When disconnect the cable, Remove lock by pulling it.

Power Connection for Re-Winding Device (Optional)

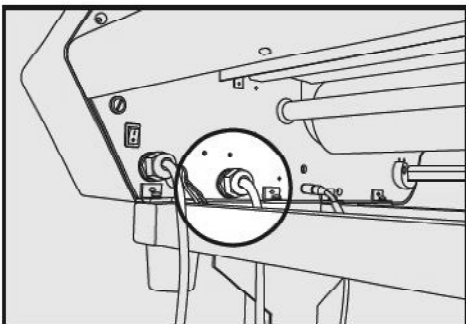

When looked from the front, insert the cable sticking out from the rear side of the main body into the power insertion hole of the re-winding device.

※ Do not insert power re-winding device cable into other power holes. It may cause device failure.

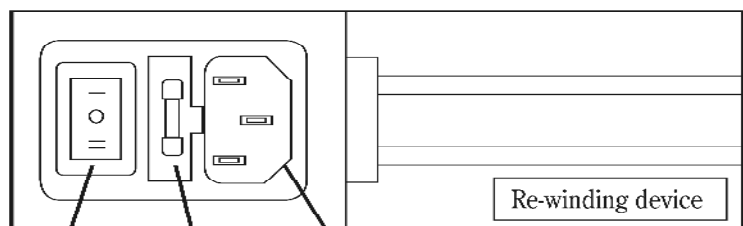

Power switch Fuse box Power inlet

DAISY -55EC /-63EC

Fuse Installation Method

Fuse is placed nearby the power switch on the rear of right surface and power switch of the Re-winding device (optional). (Spare fuse is only included in the Re-winding device.)

Take out the fuse using flat-head driver to check disconnection of the fuse.
If it is disconnected, replace with a new fuse before supplying power again.

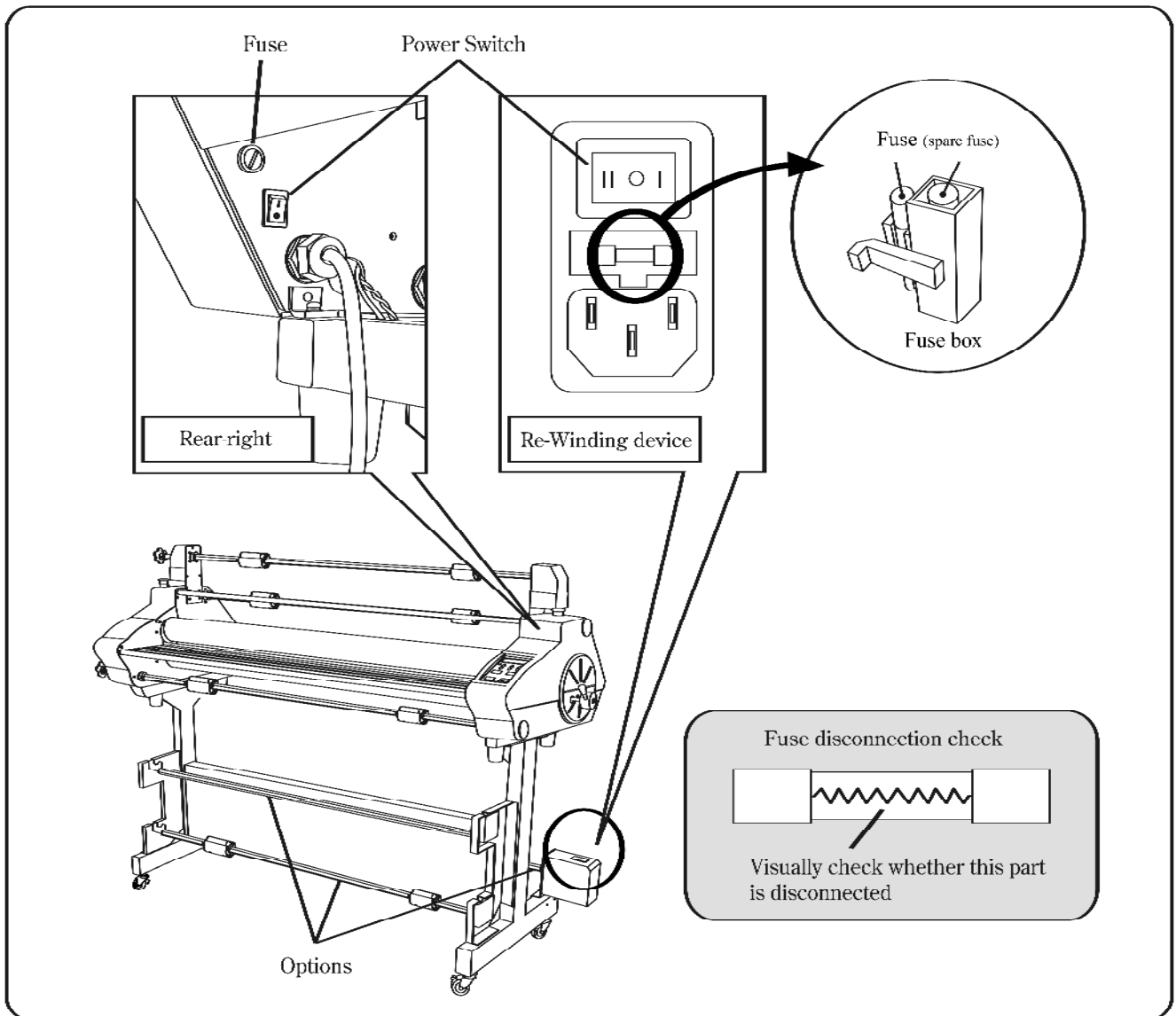

DAISY-55EC /-63EC

Name of Each Part

Main Body of DAISY-55EC/-63EC

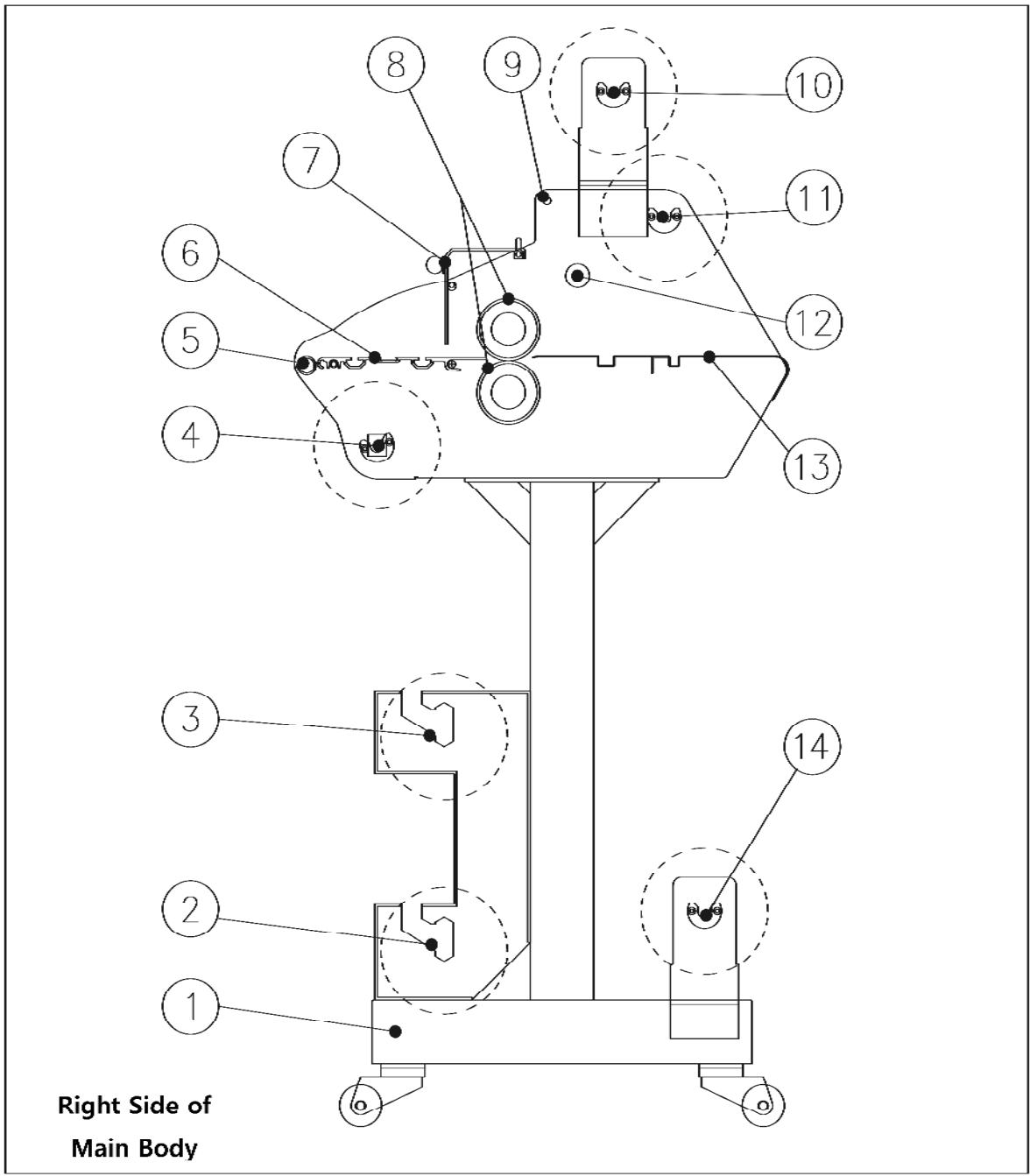

- ① Stand
- ② Reserve film shaft*
- ③ Media holder shaft*
- ④ Film shaft for under-film
- ⑤ Idle roller (front)
- ⑥ Front signboard
- ⑦ Finger jamming prevention cover
- ⑧ Laminate roll
- ⑨ Stay bar (reinforcement bar)
- ⑩ Film shaft for release paper
- ⑪ Laminate film shaft
- ⑫ Idle roller (top)
- ⑬ Back signboard
- ⑭ Re-Winding film shaft*

* ②, ③ and ⑭ are optional.

Operation Panel

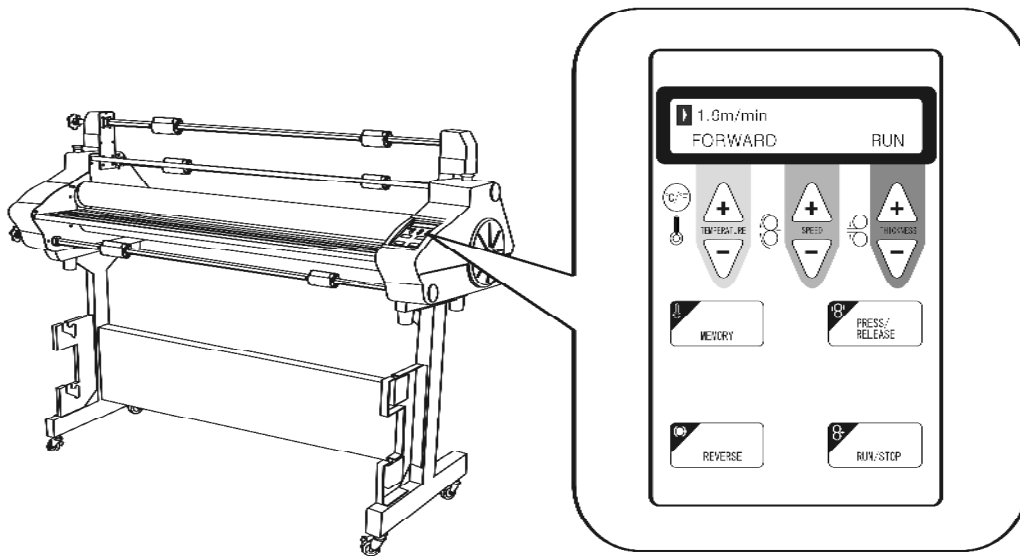

LCD Display Panel

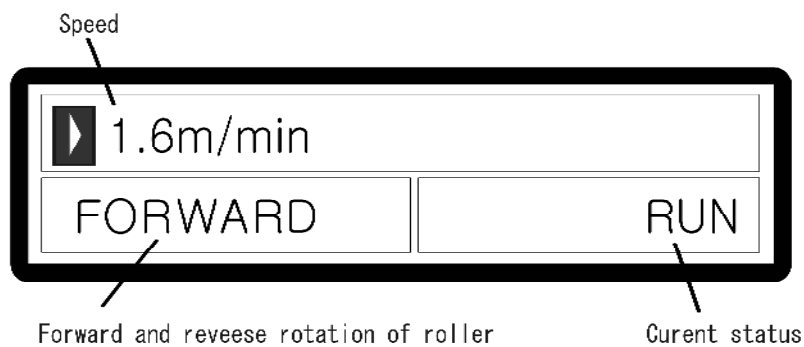

RUN

Displayed during laminate processing

STOP

Displayed when laminate processing is stopped

FORWARD

If **FORWARD** is shown on the LCD panel, the roller rotates in forward direction.

REVERSE

If **REVERSE** is shown on the LCD panel, the roller rotates in reverse direction.

EMERGENCY







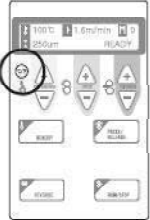

When emergency stop button is pressed, **EMERGENCY** pops up on the LCD panel.

All functions come to stop. Emergency stop can be released by turning the emergency stop button to the right.

When **EMERGENCY** is displayed, only vertical control is allowed for the roller.

- One emergency stop switch is placed on left and right sides of the top of the main body.
- Rotate the button clockwise to release emergency stop.

DAISY -55EC /-63EC

Buttons on the operating panel	
	<p>[°C/f] button This button is not used.</p>
	<p>[TEMPERATURE] button This button is not used.</p>
	<p>[SPEED] button Rotational speed of the laminate roller can be within DAISY-55EC : 0 - 3.0 m/min DAISY-63EC : 0 - 6.0 m/min</p>
	<p>[THICKNESS] button This button is not used.</p>
	<p>[MEMORY] button This button is used during maintenance to display appropriate mileage When pressed once, mileage from previous reset until now is displayed. (Press [RUN/STOP] button while pressing [MEMORY] to reset.) When pressed once again, total mileage until now is displayed. (This cannot be reset) When pressed again, it returns to the original display.</p>
	<p>[PRESS/RELEASE] button This button is not used.</p>
	<p>[REVERSE] button When pressed once, the laminate roller rotates in reverse direction When pressed once again, it returns to forward rotation.</p>
	<p>[RUN/STOP] button This button starts and stops roller rotation. The roller rotates when the button is pressed with the roller at stop, and the roller stops when the button is pressed again.</p>

⚠ Caution

- Do not operate 2 or more buttons simultaneously.
- The following buttons cannot be used on the product.
[°C/f] button, [TEMPERATURE] button, [THICKNESS] button, [PRESS/RELEASE] button

Foot Switch

This device can be operated by operation panel as well as foot switch included.

- The roller begins to rotate when the foot switch is pressed with the roller at stop.
- The roller stops rotating when the foot switch is pressed with the roller rotating.

Before Processing Laminate

About Laminate Film

There are two types of laminate film including 「roll type」 and 「pack type」.

This product uses 「cold roll film」 type.

※ 「Pack type」 and 「hot roll film」 cannot be used.

Thickness (μ)	Thickness of the laminate film is selected according to the use. Thickness of the cold roll film used by this product ranges from 20 μ to 300 μ.
Size of Branch Pipe (Inner Diameter)	Size of installable paper tube differs according to the laminate structure. This product uses a 3-inch (about 77 mm) branch pipe.
Type of Roll Film	Hot roll film Apply heat to melt glue and attach the film. Cold film Parting paper (release paper) is attached on the surface applied with glue. Release the film with the Re-winding device and compress with the roller for use.



Precautions for Handling Laminate Film

- Do not place the laminate film in places with high temperature and humidity.
- When lamination is not being done, store the film on the exclusive film shelf or in a box.
- Use film appropriate for the laminator.
- If a problem is found in the film before use, do not use and contact the store. Reckless use may result in failure of the laminator.

Cold Laminate Processing

Installation and Processing of Cold Laminate Film

[1] Install the paper tube holder on the film shaft.

All 6 film shafts are common parts.

Use hex wrench to move or fixate the branch pipe holder.

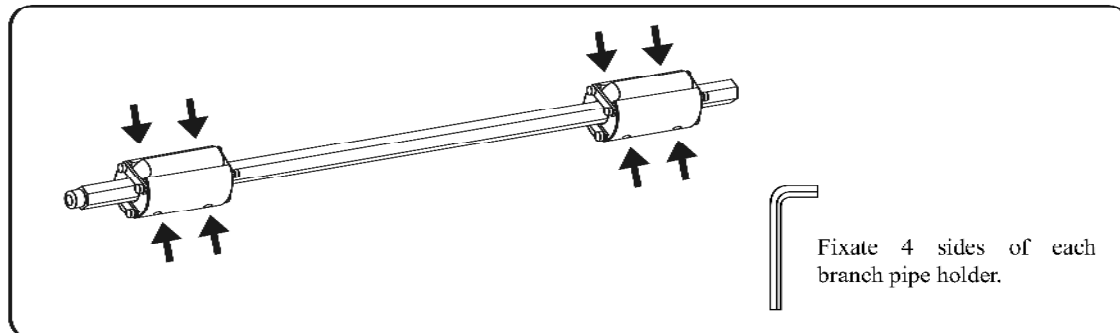

[2] Install the under-film.

Refer to the figure below to pass the under-film while laminate roller (top) is lifted.

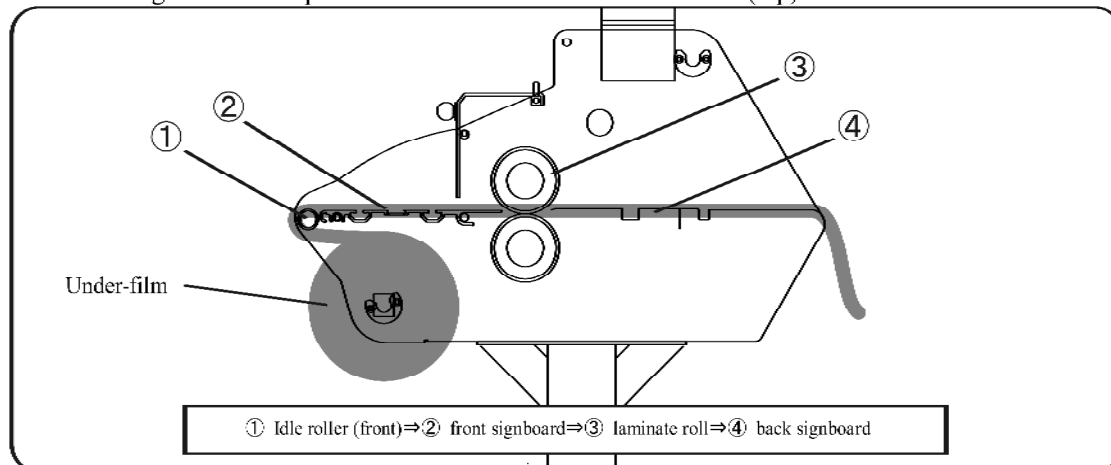

[3] Install the laminate film.

Pass the laminate roller through the under roller with the release paper attached and then put down the laminate roller.

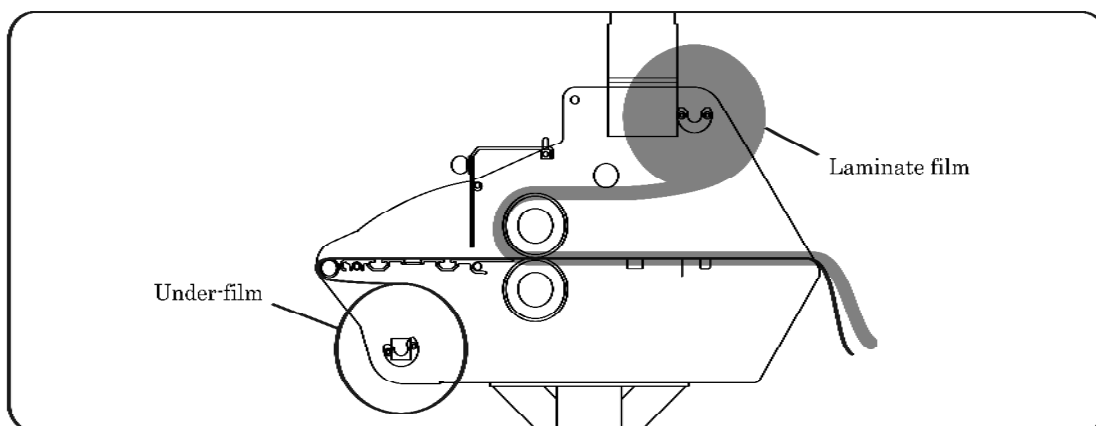

Only cut the release paper on the laminate film and rotate the laminate roller until the cross section of the release paper cut touches the re-winding paper tube.

Here, hold the release paper so that it does not get entangled.

When the release paper touches the re-winding paper tube, attach it using cellophane tape to finish installation.

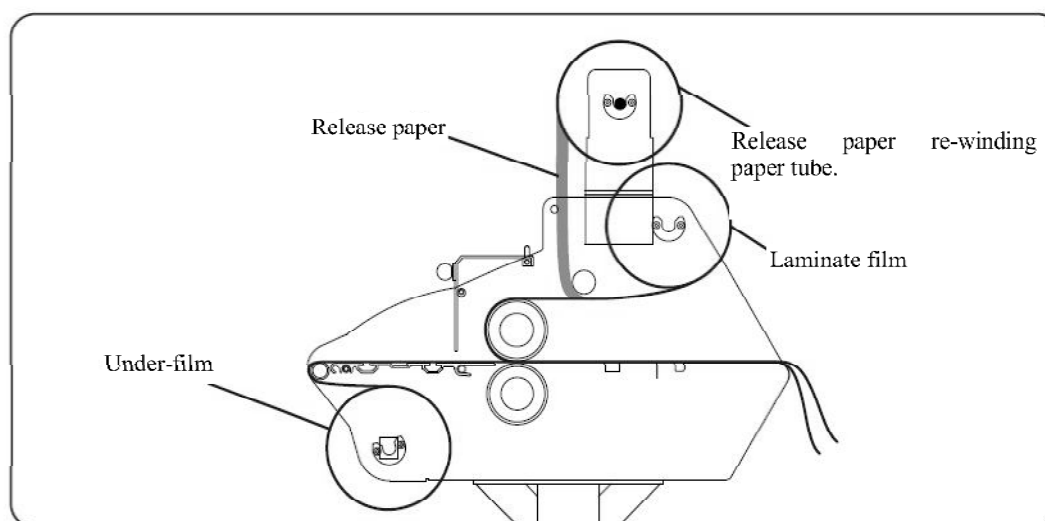

[4] Use the winding device.

If the optional re-winding device is used, install the device according to the following sequence.

Attach the laminated product to the re-winding paper tube using tape. The motor starts rotating and winding once the re-winding device switch is turned ON.

The re-winding device switch can be controlled to forward or reverse rotation.

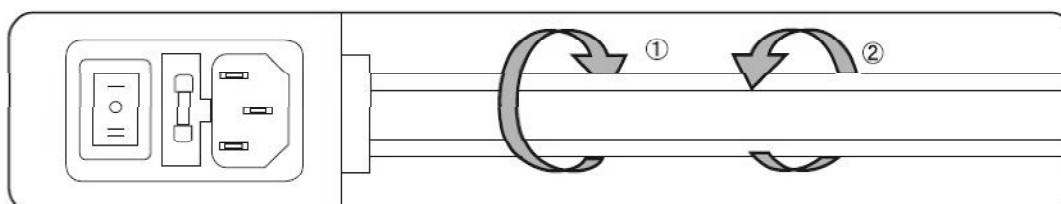

When the switch is turned to — direction, the re-winding device rotates in direction ①.

When the switch is turned to ○ direction, the re-winding device stops rotation.

When the switch is turned to = direction, the re-winding device rotates in direction ②.

Caution

- The re-winding device (optional) can be winded up to 50 m (about 30 kg).

Standard for the product of our company:

- Under-film 【PET 12 μ 1400 mm】
- Laminate film 【PVC 80 μ 1350 mm】
- Media 【PVC 80 μ 1370 mm】

During cold processing, winding is about 30 kg at 50 m.

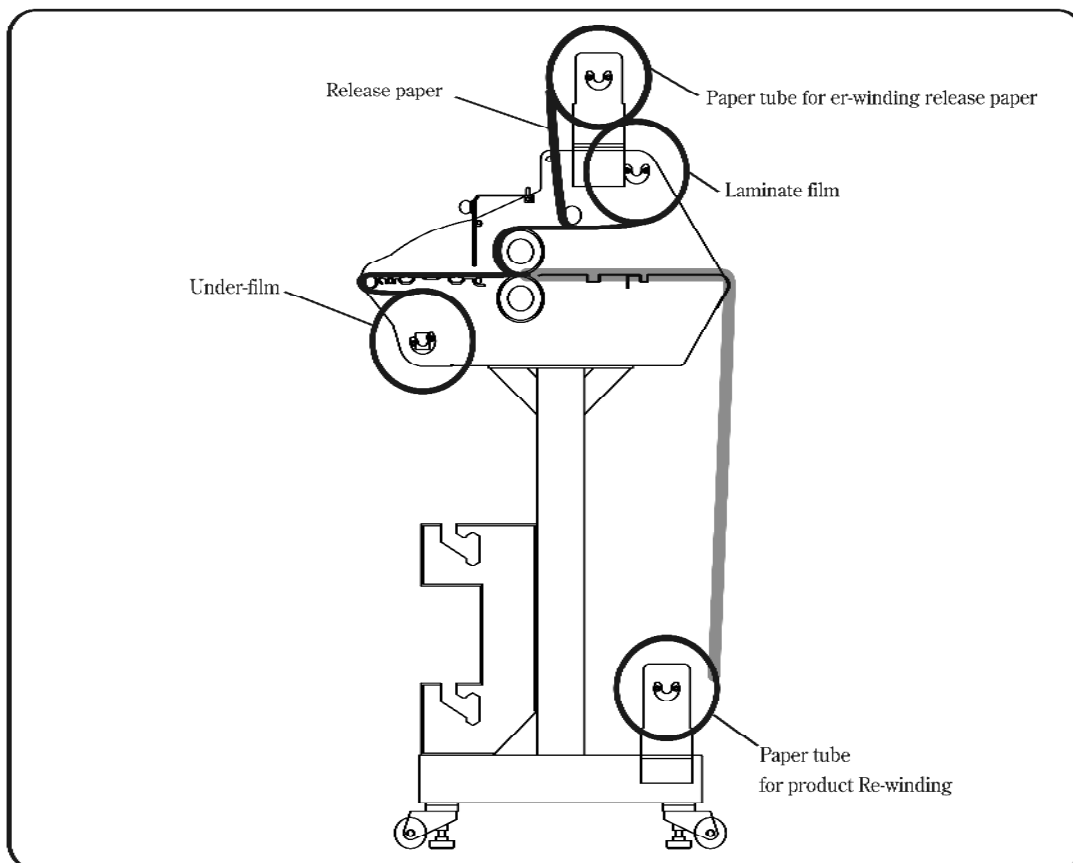

[5] Perform laminate processing.

- 1 : Use the handle to adjust pressure (gap) according to thickness of processing material.
- 2 : Adjust to the wanted speed using **[SPEED]** button (speed can be adjusted during rotation of the laminate roller) and press **[RUN/STOP]** button to rotate the laminate roller.
 - ※ Here, the re-winding device for release paper automatically rotates. The re-winding device is controlled by switch. (Refer to the above for switch operation method)
- 3 : Insert the script towards the laminate roller for laminate processing.
- 4 : Cut the processing material using cutter after processing.
- 5 : After completion of all processing works, use the handle to lift the laminate roller and cover with a cloth for storage.

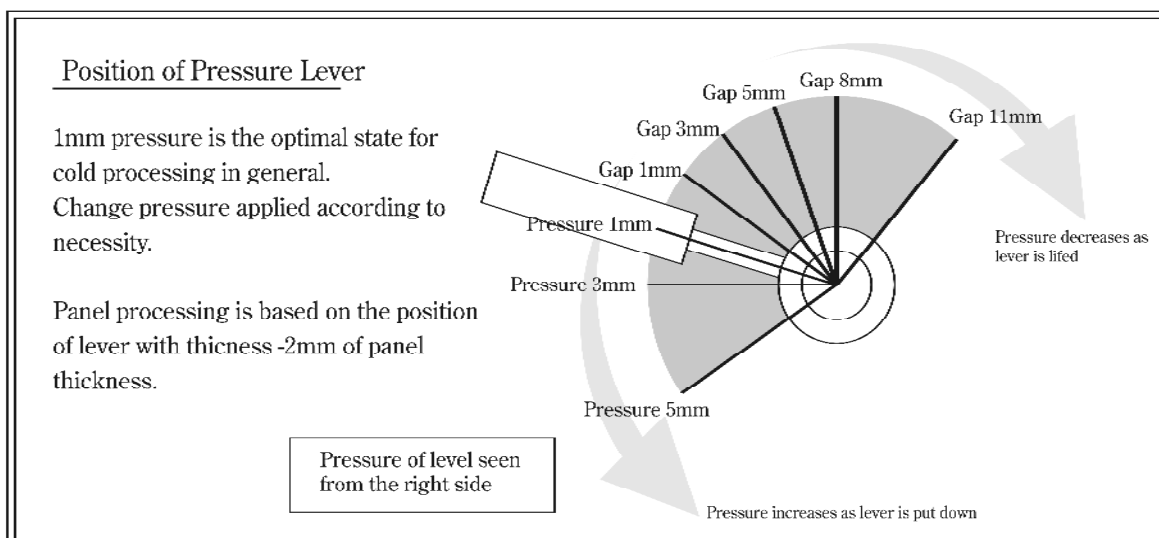

Maintenance

This product is composed of many rollers, and they must be cleaned according to usage.

The laminate can be maintained in desirable state by cleaning the rollers.

Cleaning of Roller

Clean each roller since rollers have paper scraps and dusts attached.



Caution

- The roller must be stopped when cleaning.
- Do not clean the roller using hard objects such as steel wool. They can damage the roller.
- Do not apply force on the roller for long time.
- Do not clean using thick paper, which is sometimes seen in pack type laminator. Thick paper can block the device and result in damage or failure.
Likewise, do not clean using thin paper. Paper can roll into the roller and the roller cannot be used.

Cleaning of Branch Pipe Holder

Cleanly wipe the paper tube holder using soft and dry cloth or wipe the contaminated part using cloth with water completely squeezed out. Here, applying force on wiping or cleaning with materials other than cloth can rip or damage the pipe.

Cover the product with cloth after use

After using the product, cover the main body with a large cloth to avoid dusts from entering.

Troubleshooting

The following measures are taken for troubleshooting.

Power does not turn on · machine does not function

- **Insert outlet plug and check power switch**
This product is used at 240VAC. Make sure that the outlet plug is correctly connected.
Check that the power switch on the back of the main body is turned on.
If power cable is disconnected, it must be replaced. Contact our company or store.
- **Fuse is disconnected**
Replace to a new fuse with identical spec. (Refer to P 7 for installation method.)
If the same symptom continues to occur, contact our company or store.
- **Heater or light projector is used nearby or long drum (cord reel) is used**
If such objects are in use, use power from a different system.
If a drum is used, remove the drum before connecting.
- **Overload**
Motor protection circuit may be functioning.
First remove power supply and wait for 10 seconds before resupplying power.
- **Abnormal noise from the motor**
If an abnormal noise is created by the motor, saw-tooth wheel is damaged or screw is loose.
Contact our company or store.

Product malfunctions or power is immediately turned off

- **There is a problem in wiring**
Contact our company or store.
- **PCB malfunctions because of static electricity generated inside the machine**
Turn the power off and then turn it on again.

Wrinkles are formed in the processing material

- **Laminate film and under-film are not installed properly**
Refer to P 12 ~ 15 of this document to install them properly.
- **Tension is too weak**
Strengthen tension.
- **The machine is slanted**
Reinstall it on a flat surface.

Processing material cannot be inserted · does not come out

- **Is the script too thick?**
Thickness of the script that can be processed by this product is 8 mm, including thickness of the film. If a thicker material is inserted, the roller may not rotate or get damaged. Do not try to process anything thicker than the regulated thickness. Even if thickness is within 8 mm, do not insert hard materials like metals.
- **Is film or script rolled into the roller?**
If the script remains in the insertion hole, press reverse button to pull the script out. Do not pull it too strong because excessive pulling can cause failure of the machine.
If the script is not caught in the insertion hole, contact our company or store.

Others

Product Specifications

Max. laminating width	DAISY-55EC : 1400 mm / DAISY-63EC : 1600mm
Max. substrate thickness	8 mm
Paper tube size	3 inch
Max. laminating speed	DAISY-55EC : Max. 3.0 m/min / DAISY-63EC : Max. 6.0 m/min
Interface for speed adjustment	Digital panel, variable type
Processing temperature	Room temperature
Roller clearance	Manual 8 settings
Power requirements/consumption	AC230V 100W
Size (W x D x H)	DAISY-55EC : 1943×591×1230 (mm) / DAISY-63EC : 2138×591×1230 (mm)
Weight	127 kg
Accessories	Foot switch, stand
Options	<ul style="list-style-type: none"> • Media holder shaft • Reserve film shaft • 1 set of re-winding device (Shaft + Paper tube holder + Motor)

※ Details in this document can be changed without notice to make improvements on the product.

Contact

For inquiries about the contents of this document, use the following dial.



LAMI CORPORATION INC.

URL: <http://www.lami-corporation.co.jp/english>

TEL +82-6-6453-1871